



Summary

SynQor has developed VITA 62 compliant VPX power supplies in a rugged package for military applications. The VPX power supplies are also designed to comply with MIL-STD-461F, MIL-STD-704 (level dependent), and MIL-STD-810G and the most stringent levels of VITA 47. This application note provides additional information not included in the product datasheet.

Table of Contents

1	Product Description.....	1
2	Product Topology.....	2
3	Operation.....	3
	3.1 Start-Up.....	3
	3.2 Shut-Down.....	5
	3.3 Status Signals.....	7
4	Efficiency.....	9
5	Multiple VPX in Parallel.....	11
6	Over-Temperature Protection.....	12
7	Short-Circuit Protection.....	12
8	6U VPX LED.....	12

1 Product Description

SynQor's VPX power supplies are VITA 62 compliant, high-performance, conduction cooled power supplies in both the 3U and 6U package configuration with 1.0 inch pitch. They support a nominal 28 Vdc input utilizing SynQor's field proven Mil-COTS product line.

The 3U VPX provides six standard VITA 62 outputs with a maximum total output power of 500 W over the full temperature range. The 6U VPX has two available options that provide five standard VITA 62 outputs. The 1000 W 6U VPX version has a standard input filter and the 800 W 6U VPX version has an advanced filter that also provides input transient suppression, reverse polarity protection, inrush current limit and surge protection.

The main outputs for all versions feature active current sharing through a backplane connection for high power paralleled applications. The auxiliary outputs can also be connected together for redundancy but they do not have current sharing capabilities.

The SynQor VPX Power Supply is designed to comply with MIL-STD-461F, MIL-STD-704 (level dependent), and MIL-STD-810G. It has also been qualified to the most stringent levels of VITA 47. It is available in two separate screening levels with conformal coating as an additional option.

2 Product Topology

The SynQor VPX Power Supply utilizes Mil-COTS filter and converters. In the 3U VPX supply, an internal passive EMI filter is present. There is one main isolated DC-DC converter to generate the 12 V output followed by non-isolated DC-DC converters to generate other output voltages. In the 6U VPX supply, either passive or active filters are present depending on the model. Isolated DC-DC converters are used to generate the 12 V output and 3.3 V auxiliary output, and non-isolated converters are used to generate other outputs.

The SynQor 28 Vin VPX is isolated from input to output with an isolation voltage of 1500 V. Its input and output are also isolated from chassis with an isolation voltage of 1500 V.

All of the outputs share a common ground.

Block Diagram for the VPX-6U-DC28P-001

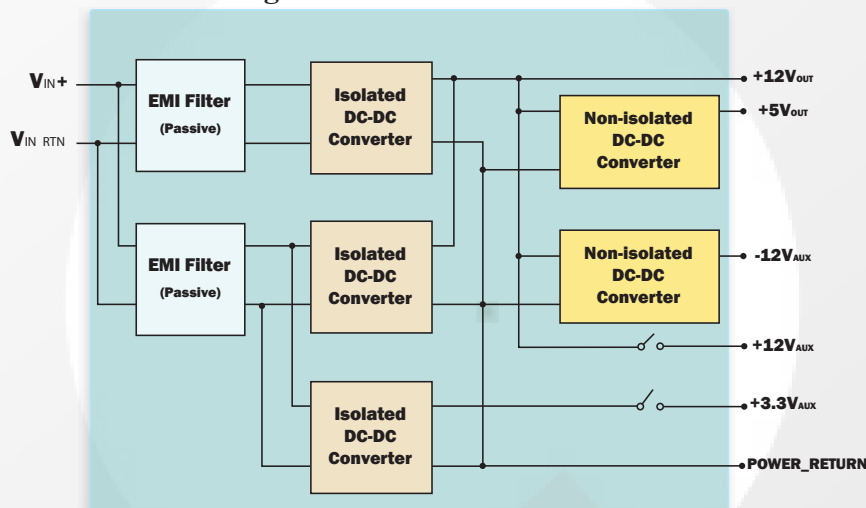

Block Diagram for the VPX-3U-DC28P-001

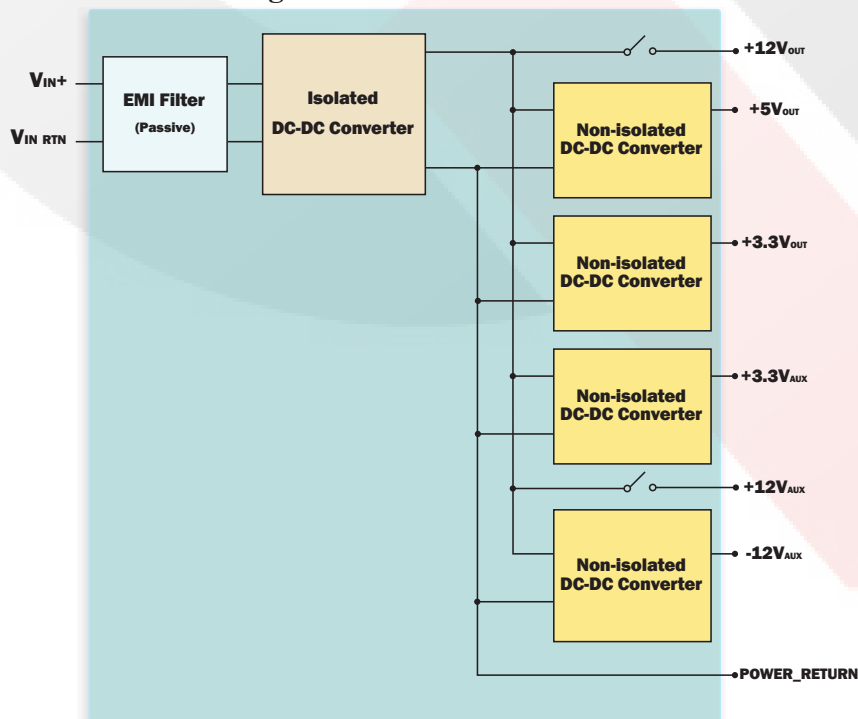

3 Operation

3.1 Start-Up

SynQor VPX Power Supply has standard VITA 62 Control States.

VITA 62 CONTROL STATES

ENABLE*	INHIBIT*	+3.3V_AUX	VS1, VS2, VS3, +12V_AUX, -12V_AUX
HIGH	HIGH	OFF	OFF
LOW	HIGH	ON	ON
HIGH	LOW	OFF	OFF
LOW	LOW	ON	OFF

If ENABLE* is LOW and INHIBIT* is HIGH when input voltage is applied, the +3.3V_AUX output will turn on first. After 100 ms, all other outputs will turn on. Figures 1-4 show the typical startup sequence when input voltage is applied and ENABLE* is configured LOW and INHIBIT* HIGH.

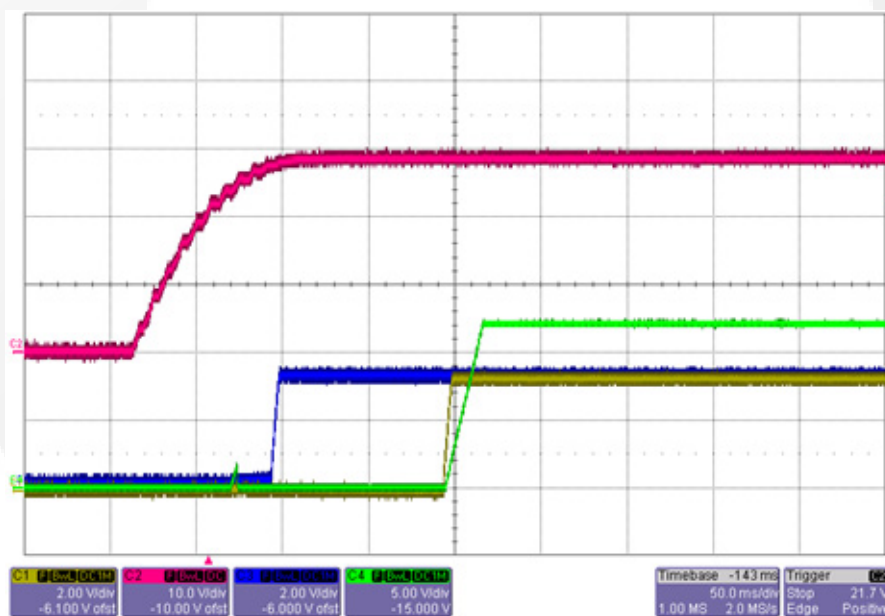

Figure 1: 3U VPX typical startup waveform, $V_{in}=28\text{ V}$, $T=25\text{ }^{\circ}\text{C}$

- CH 1: +3.3V_Main (yellow)
- CH 2: Input Voltage (pink)
- CH 3: +3.3V_AUX (blue)
- CH 4: +12V_Main (green)

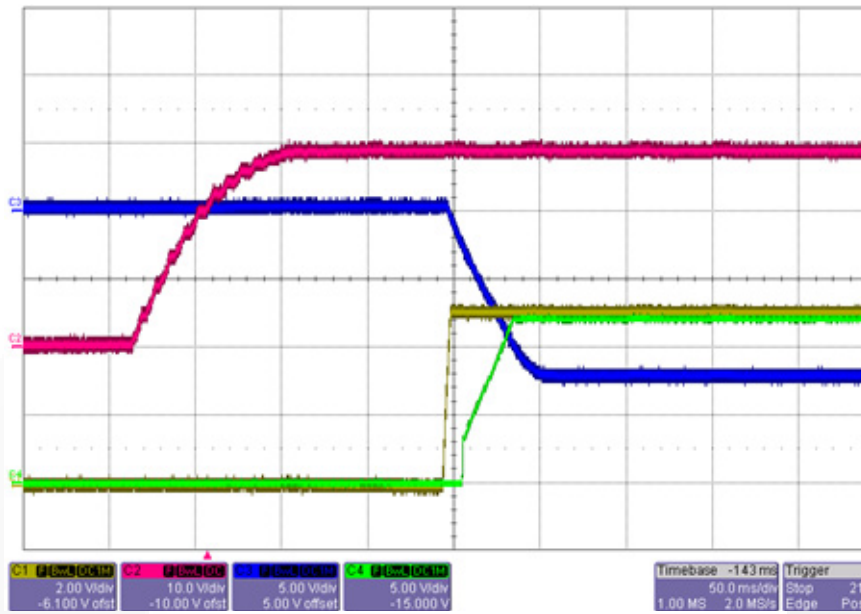

Figure 2: 3U VPX typical startup waveform, $V_{in}=28\text{ V}$, $T=25\text{ }^{\circ}\text{C}$

- CH 1: +5V_Main (yellow)
- CH 2: Input Voltage (pink)
- CH 3: -12V_AUX (blue)
- CH 4: +12V_AUX (green)

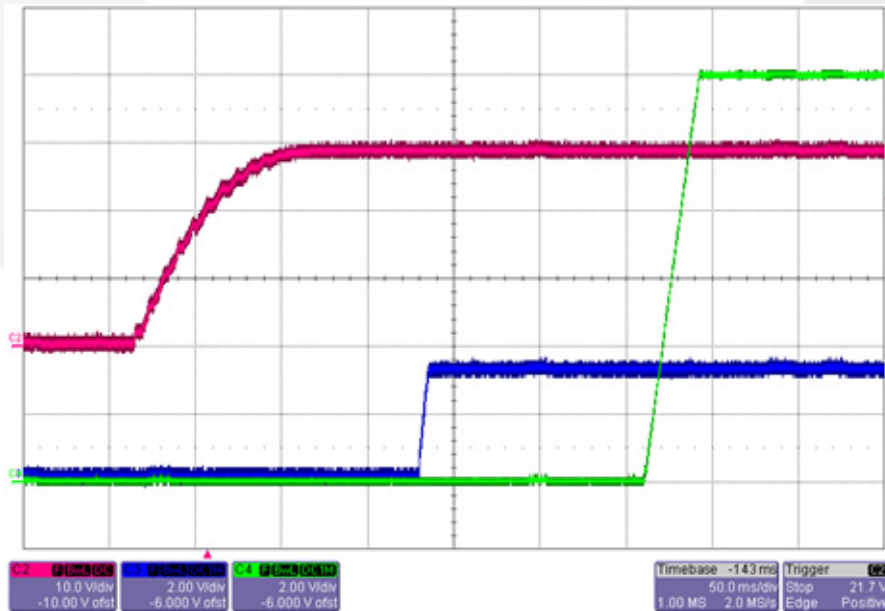

Figure 3: 6U VPX typical startup waveform, $V_{in}=28\text{ V}$, $T=25\text{ }^{\circ}\text{C}$

- CH 2: Input Voltage (pink)
- CH 3: +3.3V_AUX (blue)
- CH 4: +12V_Main (green)

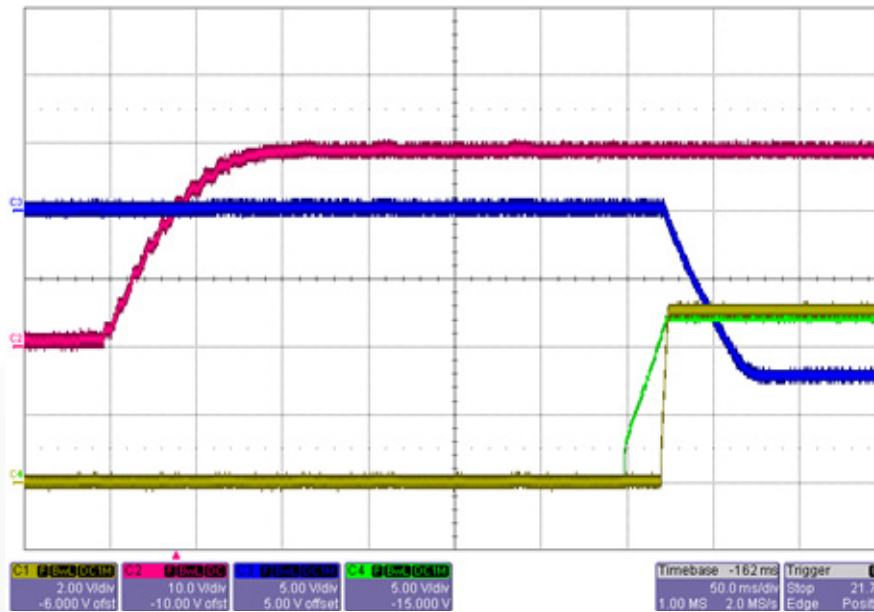

Figure 4: 6U VPX typical startup waveform, $V_{in}=28\text{ V}$, $T=25\text{ }^{\circ}\text{C}$

CH 1: +5V_Main (yellow)
 CH 2: Input Voltage (pink)
 CH 3: -12V_AUX (blue)
 CH 4: +12V_AUX (green)

3.2 Shut-Down

If ENABLE* becomes HIGH or input UVLO is triggered, all outputs will shut down at the same time. Figures 5-8 show the typical shut down waveforms when input voltage is removed.

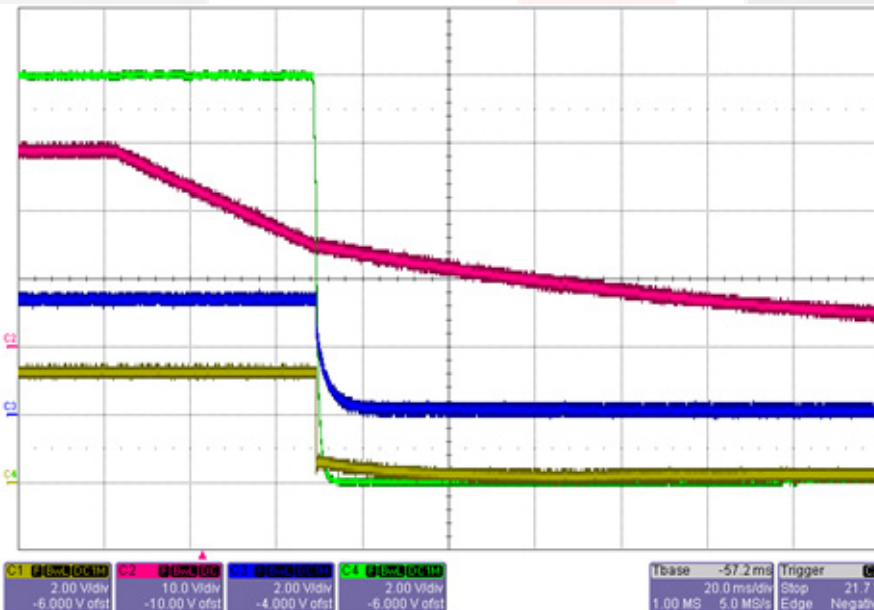

Figure 5: 3U VPX typical shutdown waveform, $V_{in}=28\text{ V}$, $T=25\text{ }^{\circ}\text{C}$

CH 1: +3.3V_Main (yellow)
 CH 2: Input Voltage (pink)
 CH 3: +3.3V_AUX (blue)
 CH 4: +12V_Main (green)

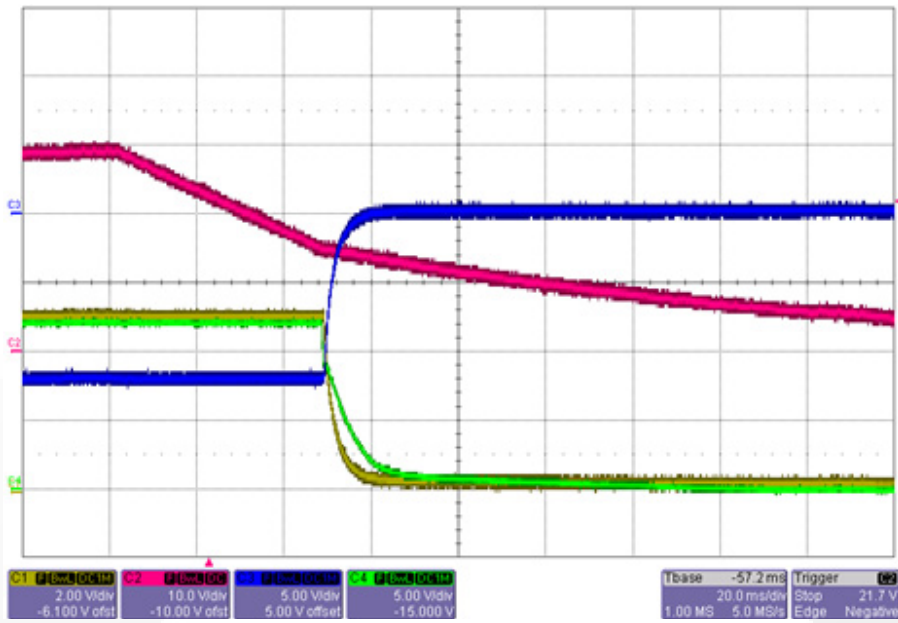

Figure 6: 3U VPX typical shutdown waveform, $V_{in}=28\text{ V}$, $T=25\text{ }^{\circ}\text{C}$

- CH 1: +5V_Main (yellow)
- CH 2: Input Voltage (pink)
- CH 3: -12V_AUX (blue)
- CH 4: +12V_AUX (green)

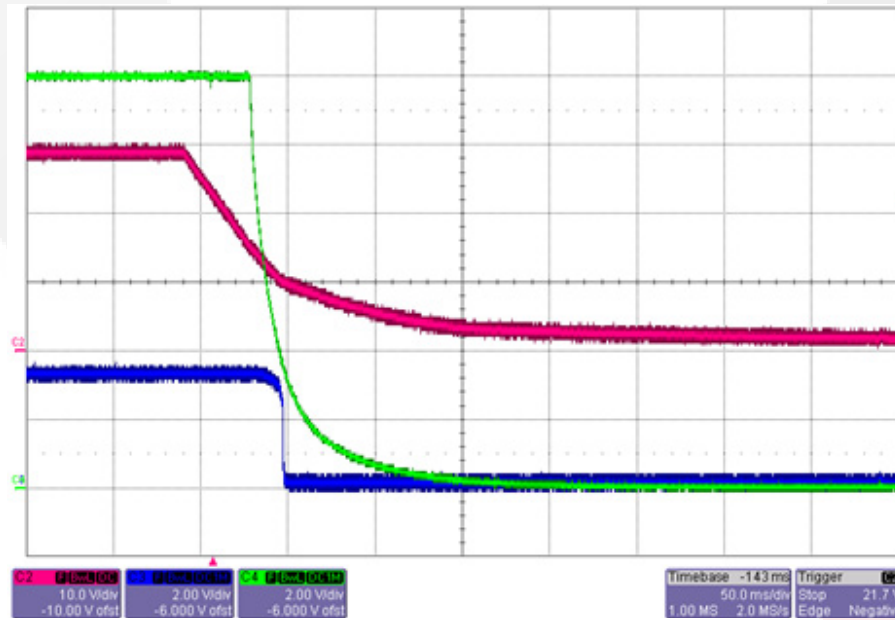

Figure 7: 6U VPX typical shutdown waveform, $V_{in}=28\text{ V}$, $T=25\text{ }^{\circ}\text{C}$

- CH 2: Input Voltage (pink)
- CH 3: +3.3V_AUX (blue)
- CH 4: +12V_Main (green)

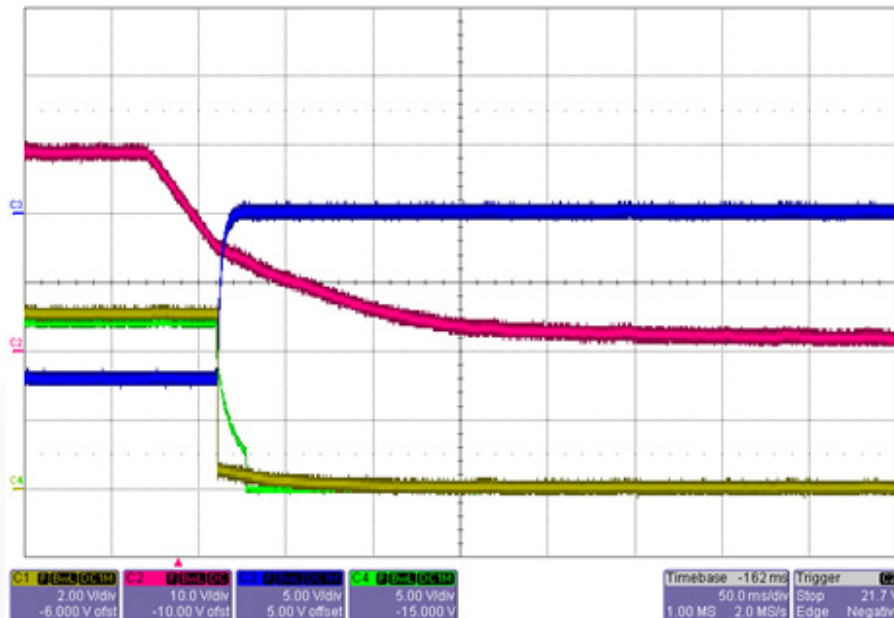

Figure 8: 3U VPX typical shutdown waveform, $V_{in}=28\text{ V}$, $T=25\text{ }^{\circ}\text{C}$

CH 1: +5V_Main (yellow)
 CH 2: Input Voltage (pink)
 CH 3: -12V_AUX (blue)
 CH 4: +12V_AUX (green)

3.3 Status Signals

- **FAIL***: FAIL* is an active low open-drain output generated by the module. It is used to indicate that a failure has occurred. FAIL* will be pulled low when any of the outputs are outside of the voltage. At power-on, FAIL* is high impedance.
- **SYSRESET***: SYSRESET* is an active low open-drain output generated by the module. It is used to indicate that startup has completed. At power-on, SYSRESET* is pulled low and will be high impedance once all outputs are within the specified voltage range. SYSRESET* will be pulled low if any failure has occurred or if the outputs are disabled by the user during operation.

The following figures show the typical startup waveforms. FAIL* and SYSRESET* are pulled up +3.3V_AUX on the backplane. ENABLE* is LOW and INHIBIT* is HIGH.

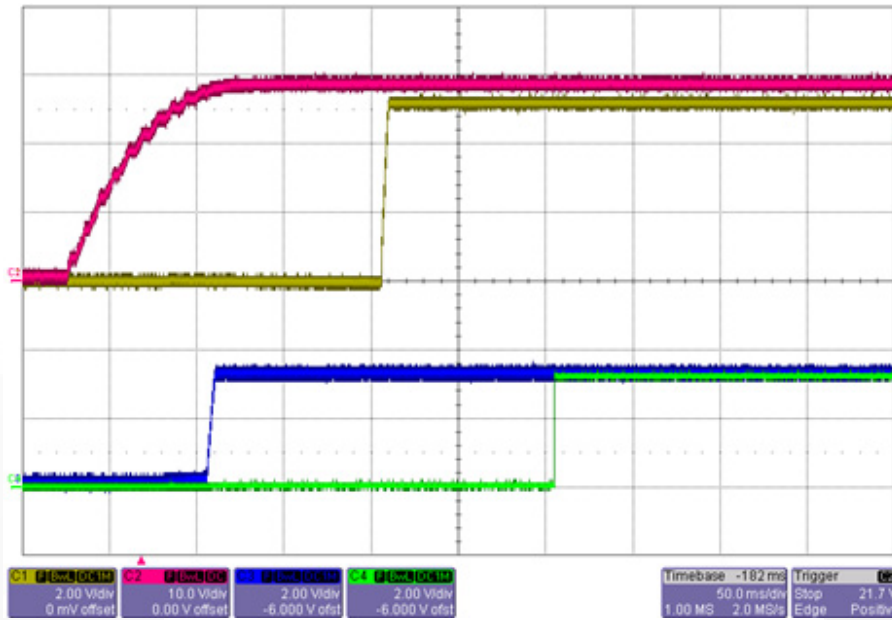

Figure 9: 3U status signals on startup, $V_{in}=28\text{ V}$, $T=25\text{ }^{\circ}\text{C}$

- CH 1: +5V_Main (yellow)
- CH 2: Input Voltage (pink)
- CH 3: FAIL* (blue)
- CH 4: SYSRESET* (green)

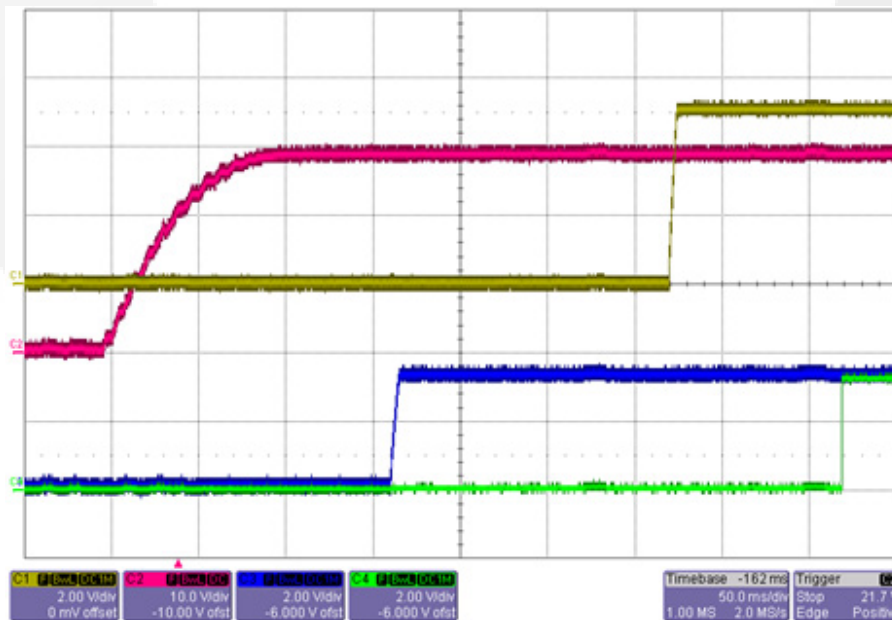

Figure 10: 6U status signals on startup, $V_{in}=28\text{ V}$, $T=25\text{ }^{\circ}\text{C}$

- CH 1: +5V_Main (yellow)
- CH 2: Input Voltage (pink)
- CH 3: FAIL* (blue)
- CH 4: SYSRESET* (green)

4 Efficiency

The SynQor VPX efficiency varies with input voltage and load configuration. Efficiency is higher when more power is drawn from the +12V_MAIN. The following efficiency charts show detailed performance of the power supply.

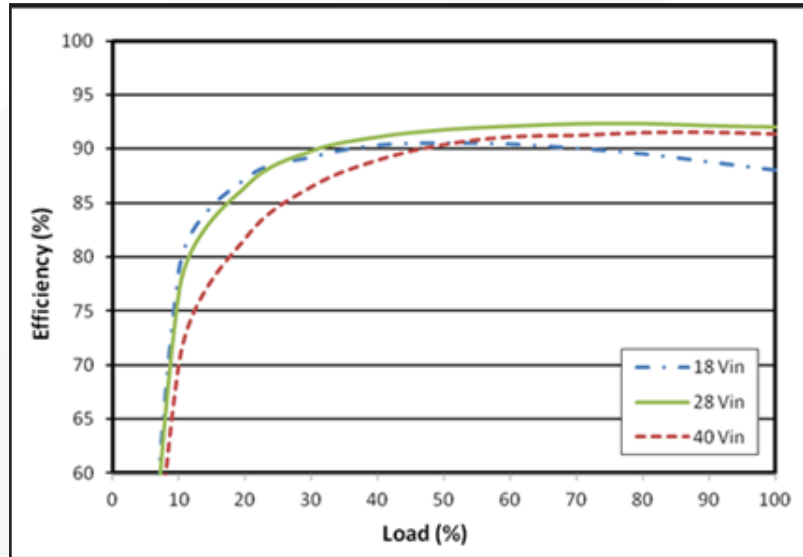

Figure 11: VPX-3U-DC28P efficiency when only +12V_MAIN is loaded

Note: 100 % load is defined as +12V_MAIN at 40 A. Total output power is 480 W.

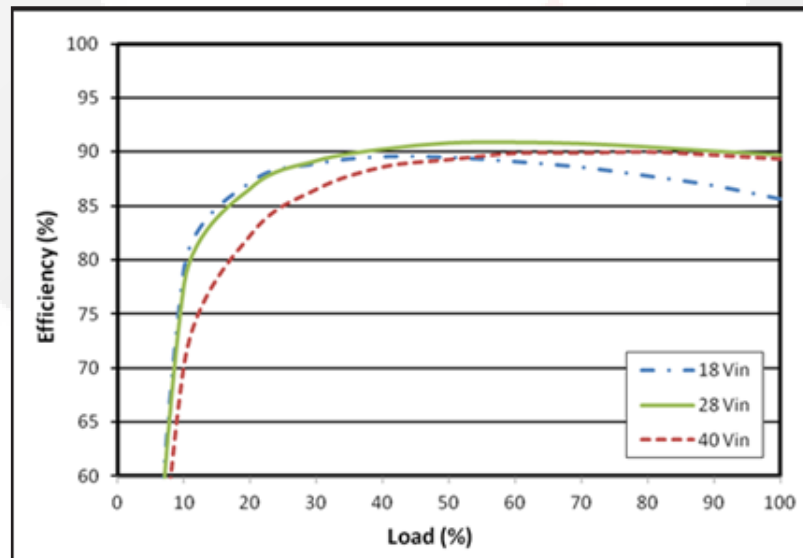

Figure 12: VPX-3U-DC28P efficiency when +12V_MAIN and +5V_MAIN are loaded

Note: 100 % load is defined as +12V_MAIN at 29 A and +5V_MAIN at 30 A. Total output power is 498 W.

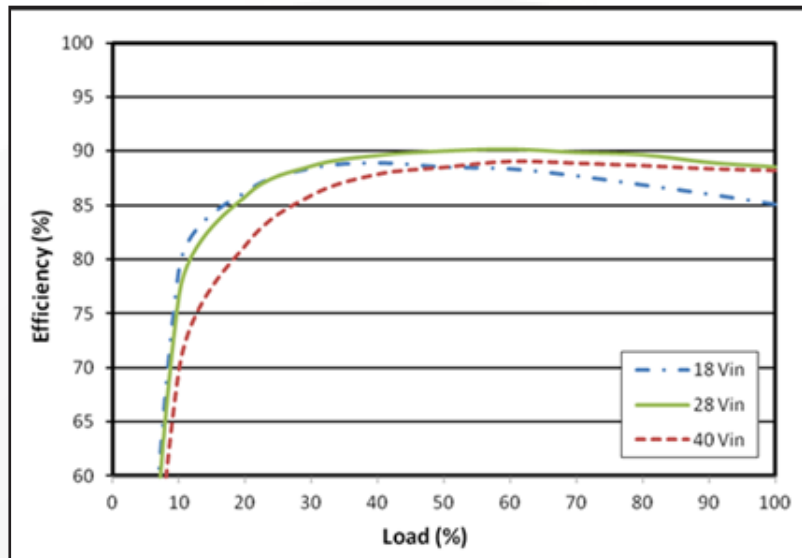

Figure 13: VPX-3U-DC28P efficiency when +12V_MAIN, +5V_MAIN and +3.3V_MAIN are loaded

Note: 100 % load is defined as +12V_MAIN at 22 A, +5V_MAIN at 30 A and +3.3V_MAIN at 20 A. Total output power is 480 W.

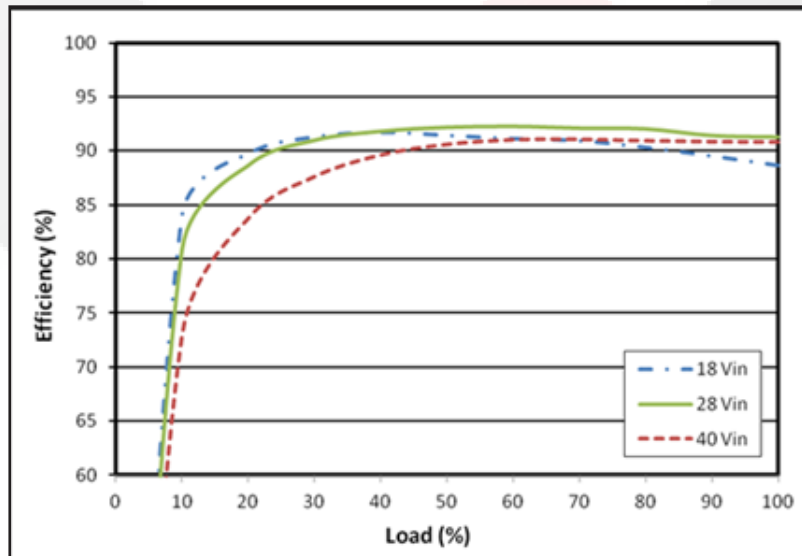

Figure 14: VPX-6U-DC28P efficiency when +12V_MAIN and +5V_MAIN are loaded

Note: 100 % load is defined as +12V_MAIN at 70 A and +5V_MAIN at 30 A. Total output power is 990 W.

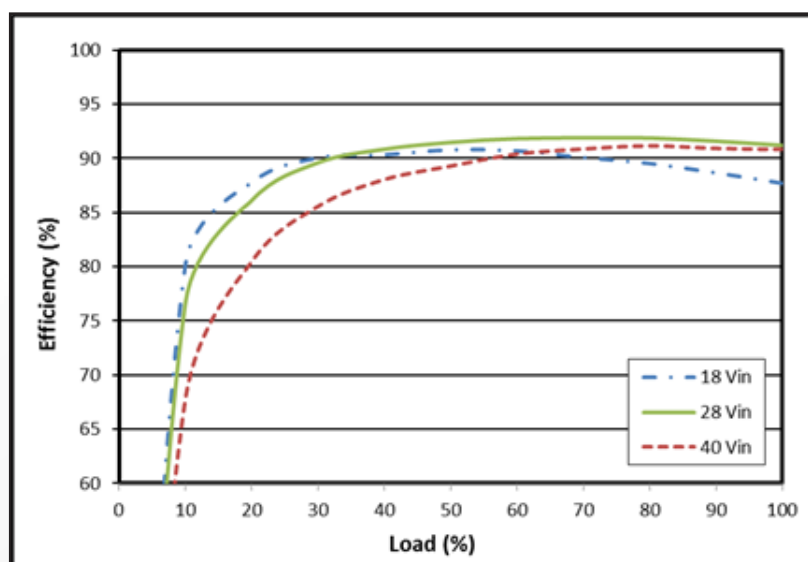

Figure 15: VPX-6U-DC28T efficiency when +12V_MAIN and +5V_MAIN are loaded

Note: 100 % load is defined as +12V_MAIN at 54 A and +5V_MAIN at 30 A. Total output power is 798 W.

5 Multiple VPX Power Supplies in Parallel

SynQor VPX Power Supplies can be operated in parallel. Active current sharing is supported on the three main outputs. ENABLE*, INHIBIT* and STARTUP_SYNC should be connected together for parallel operation. Current sharing is not supported on auxiliary outputs. However, all the auxiliary outputs have OR'ing MOSFETs or OR'ing diodes implemented, so that they can still be connected together for redundancy. Total output current on these rails should not exceed the current rating of a single module.

+12V_MAIN: SynQor uses digital signals to provide current sharing functions on the +12V_MAIN output. The +12V_SHARE(+) and +12V_SHARE(-) pins should be routed between all paralleled modules as differential pairs. One VPX power supply is dynamically chosen to act as a master, controlling all the other power supplies. High speed data communication is transmitted on the two share lines. The control state is transmitted between the master supply and slave supplies on a cycle-by-cycle basis. Adding capacitance to the share lines must be avoided.

This current share scheme does not provide glitch-free redundancy on the +12V_MAIN output. If a failure occurs to the master supply, all supplies will shut down and the remaining working supplies will automatically restart regardless of the amount of load current being drawn by the system. Alternatively, if a failure occurs to a slave module, and total load current on +12V_MAIN can be supported by the rest of the modules, there will be no disturbance to the output voltage. Note that the master is chosen automatically by the modules and cannot be determined by the user.

+5V_MAIN and +3.3V_MAIN (if present): Active current sharing is also supported for these outputs, but with an analog sharing scheme. The +5V_SHARE and +3.3V_SHARE pins are referenced to POWER_RETURN. A clean ground plane is important. Voltage drops between supplies should be minimized. Unlike +12V_MAIN output, glitch-free redundancy can be achieved on these two outputs. If one module fails and total load current can be supported by the rest of the modules, there will be no disturbance to the output voltage.

6 Over-Temperature Protection

Each converter used inside the VPX has its own over-temperature shutdown protection. The trip level is set to limit damage to the converter during an over-temperature event, around 120 °C at the internal sensor. The temperature at the VPX rails when the internal protection trips will vary with the amount of power dissipated within the unit.

+12V_MAIN: If over-temperature occurs on +12V_MAIN supply, ALL outputs will shut down (with the exception of +3.3V_AUX on the 6U modules). The VPX module will go through a startup sequence upon recovery from over-temperature on +12V_MAIN output.

All other outputs: Only the output that trips its over-temperature protection will shut down and no other output will be affected. The specific output that shuts down due to over-temperature protection will automatically restart upon recovery from over-temperature.

7 Short-Circuit Protection





Each output of the VPX module has short-circuit protection, and the VPX will automatically return to work after short-circuit is removed.

+12V_MAIN: If a short-circuit occurs on +12V_MAIN output, ALL outputs will shut down (with the exception of +3.3V_AUX on the 6U supply). The VPX power supply will automatically recover and go through startup sequence once short-circuit on +12V_MAIN is removed.

All other outputs: Only the output that trips short-circuit protection will shut down and no other output will be affected. The specific output that shutdown due to short-circuit protection will automatically restart once short-circuit on that output is removed

8 6U VPX LED Indicator

There is an LED status indicator on the 6U VPX power supply. It has following possible indications, according to the table below:

LED Appearance	Description	Indication
	Red	Input applied, all outputs are disabled (ENABLE* High; INHIBIT* Low)
	Amber	+3.3V_AUX is enabled, all other outputs are disabled (ENABLE* Low; INHIBIT* Low)
	Green	All outputs are enabled and there is no fault condition
	Blinking Red	VPX has a fault condition
	Off	No input applied or LED disabled by user